

Hydrogen production from sustainable sources

Javier Brey, Hynergreen Technologies, S.A.

December 9th, 2010

- Hynergreen's overview
- Why renewable Hydrogen?
- Facing the Hydrogen Economy
- Renewable Hydrogen production

- Hynergreen's overview
- Why renewable Hydrogen?
- Facing the Hydrogen Economy
- Renewable Hydrogen production

Hynergreen Technologies, S.A. is a subsidiary of Abengoa. Its objective is the organisation and development of business and activities related to electricity production by means of fuel cells based on different technologies, as well as the use of hydrogen.

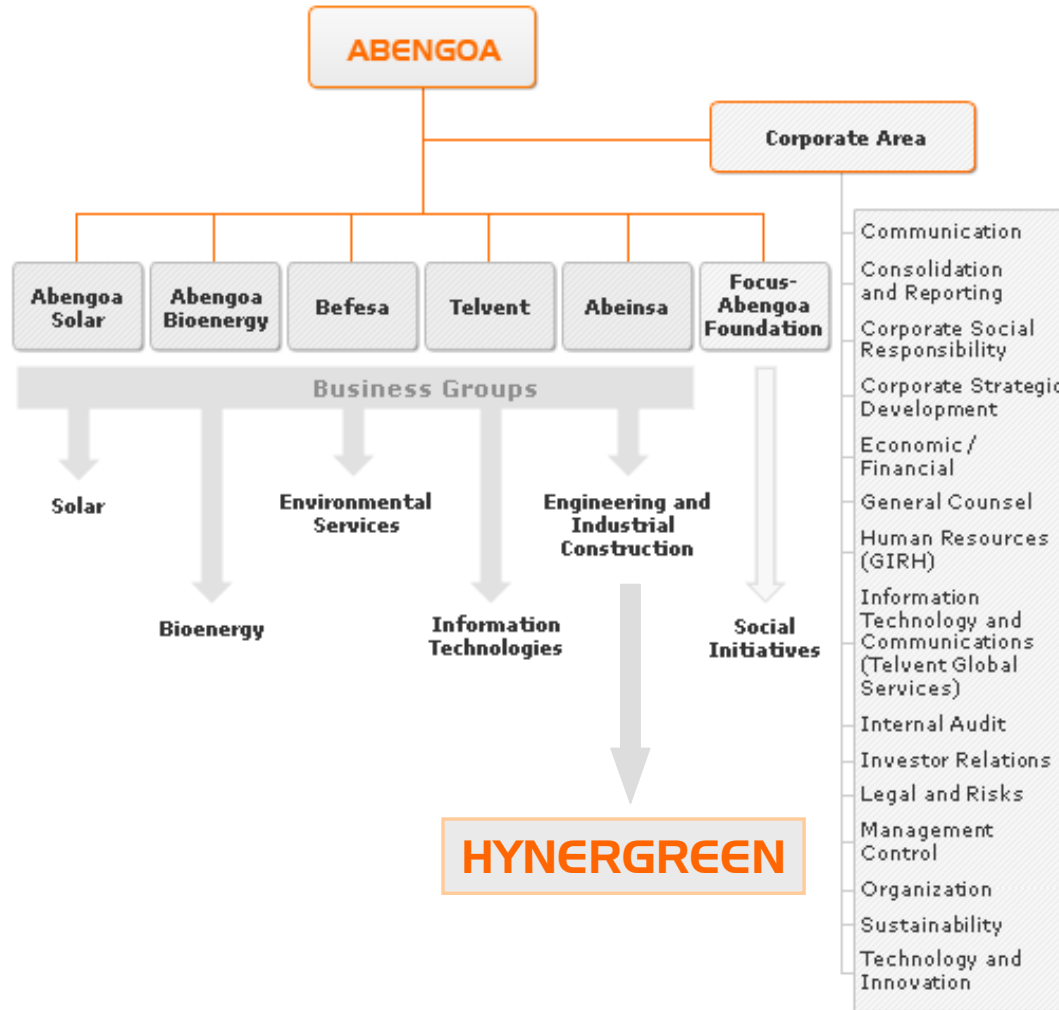

Renewable hydrogen

The production of clean hydrogen from renewable energy sources, and its treatment, purification, storage and subsequent use. Hydrogen and fuel cells are not themselves clean or sustainable. This is an aspect that depends on the origin of the fuel (hydrogen); therefore, it is important that the production of a clean, sustainable and local hydrogen that contributes to the development of renewable energy sources be achieved.

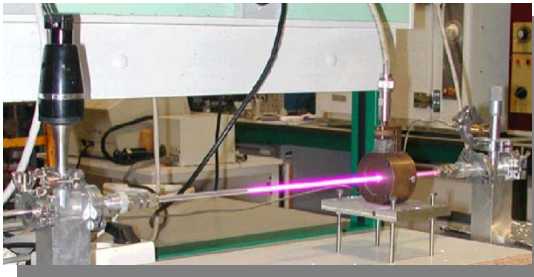

The integration of renewable energy sources with the "Hydrogen Vector". Projects to produce hydrogen from solar energy (both thermal and photovoltaic), wind power, etc.

Clean electricity production by means of fuel cells



The pursuit of new fuel cell applications, utilizing different technologies: telecommunication installations, residential and stationary applications, and the transport sector. The “market niches” that, in the medium and long-term, will most benefit from the introduction of fuel cells, are being analyzed.

The development of new fuel cells. Reversible, compact, and direct, for specific applications with very specific features, etc. The company is collaborating with different fuel cell manufacturers, defining parameters and assessing prototypes, and work is also in progress on the standardization of these devices on the fuel cell Standardization Committee, in the national and international environments.



Hynergreen belongs to the Spanish standardization Subcommittee AEN/CTN206/SC105 "Fuel Cells", and also participates in the international Technical Committees IEC/TC105.



Hynergreen holds the office of Vice-chairman of both APPICE and AeH2, the Spanish Fuel Cell and Hydrogen Associations, respectively.

Hynergreen holds the chairmanship of the Spanish Hydrogen and Fuel Cell Technology Platform (PTE HPC).



Hynergreen is a founding member of the Fuel Cells and Hydrogen Joint Technology Initiative (JTI) Industry Grouping.

- Hynergreen's overview
- Why renewable Hydrogen?
- Facing the Hydrogen Economy
- Renewable Hydrogen production

Are Hydrogen and Fuel Cells renewable?

- It is often talked about the goodness of hydrogen as an energy carrier, or about fuel cells as a device for clean electricity production; in this way, it is common to associate both terms to “renewable energy”, nevertheless this last aspect is not always correct
- Hydrogen will be “clean”, or not, depending on the way it has been produced, and fuel cells will be a renewable energy source, or not, just if that’s the case of the fuel fed to them

Are Hydrogen and Fuel Cells renewable?

- Clean hydrogen production by means of renewable sources is, without any doubt, an important aspect to be taken into account on the way to the real launch of this gas as an “energy vector” for the future, by a Society that demands, increasingly, a “sustainable development”
- Hydrogen can also be used as a storage medium, complementing each other with “traditional” renewable energy sources, as solar (both photovoltaic and thermosolar) and wind energy. In such a way, “surplus electricity” could be stored in the form of hydrogen, in order to use it when appropriate

Why renewable Hydrogen?

- Systems integration employing fuel cell technology is considered as a solution for the variability on the electricity production by means of renewable energy sources, as it's the case for solar and wind energy

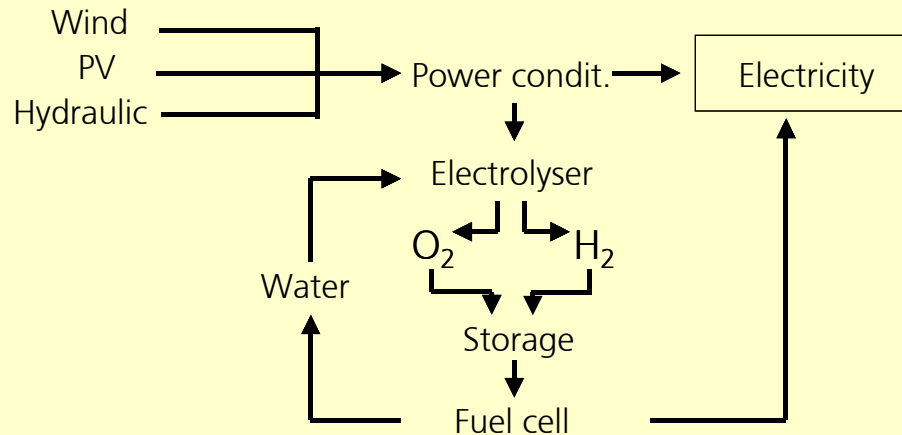

Why renewable Hydrogen?

- “Clean” hydrogen production by means of renewable energy sources could be the solution for a decentralized or isolated hydrogen production

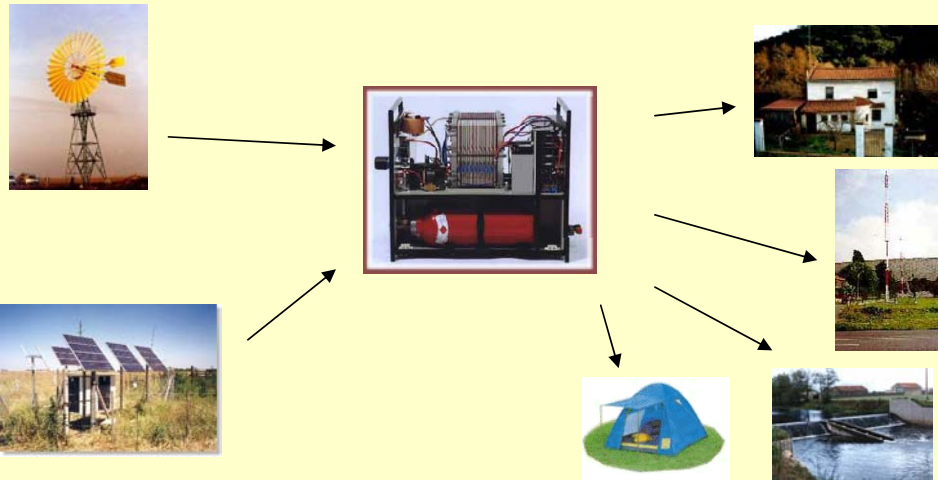

Why renewable Hydrogen?

- This combined use of hydrogen as an electricity buffer, and the capability of a distributed production and storage, will favour the prevention of blackouts, when excessive demand peaks may arise

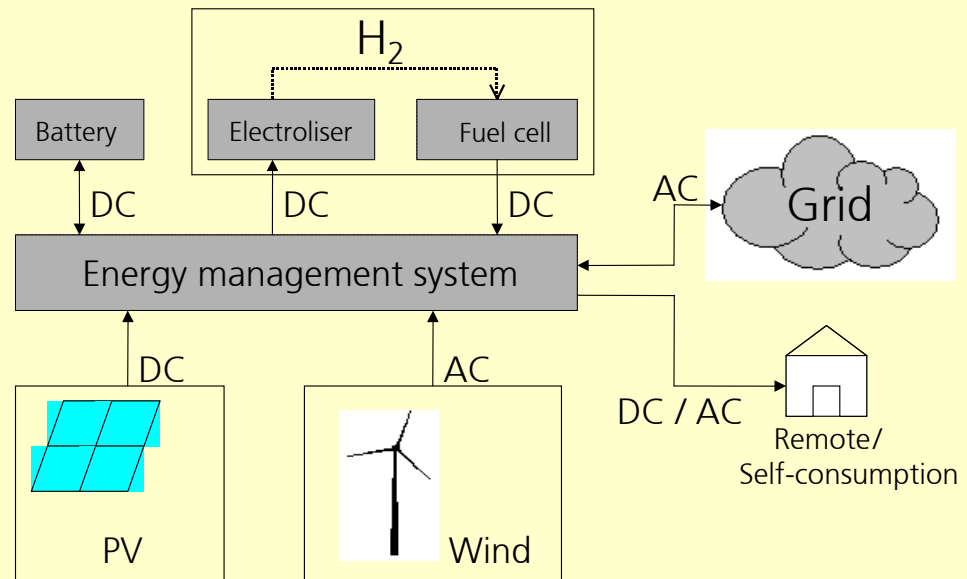

Why renewable Hydrogen?

- Hydrogen production by means of many diverse renewable energy sources, depending on each individual case, is what converts hydrogen in a fuel that can be produced locally, making its economy non dependent from petrol imports

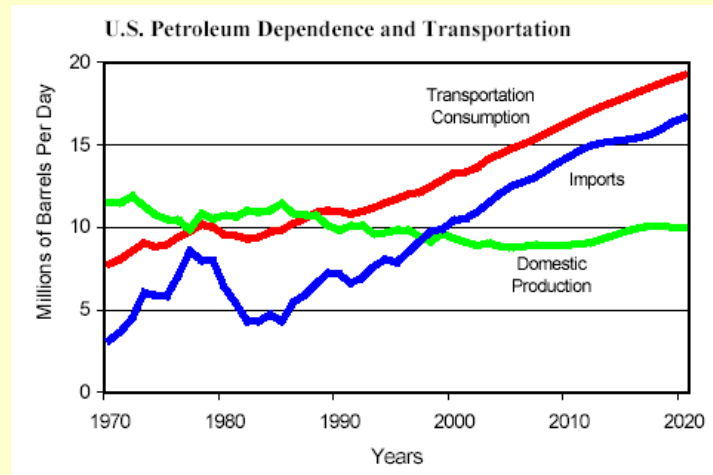

Why renewable Hydrogen?

- There are different reasons, depending on the country, for promoting the migration to the Hydrogen Vector; in many cases, this reason is the desire of mitigating greenhouse gases emissions (Kyoto Protocol); this could be achieved by using "green" hydrogen

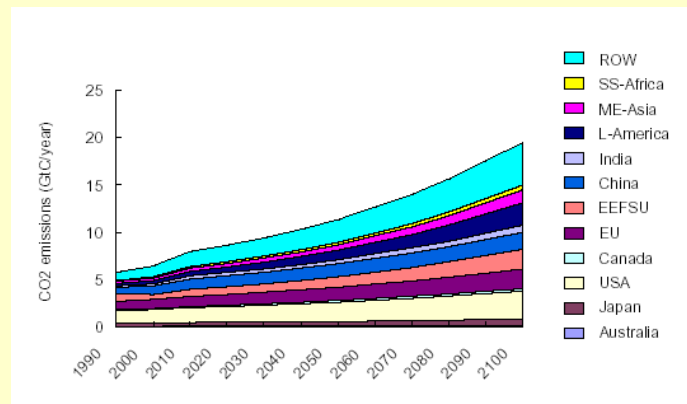

Why renewable Hydrogen?

- Back-up functions (special services, blackouts, etc.)
- Energy storage during off-peaks hours, in order to cover peak power demand afterwards
- Surplus energy storage, that can not be sold to the grid

~~Substitution?
Competition?~~

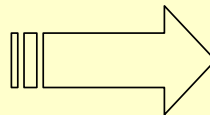

**Cooperation
between
technologies**
RES \leftrightarrow H₂ FC

In conclusion (I)

Hydrogen is a combustible gas, exhausting water as its only byproduct.

The fact that hydrogen is not a resource, but a fuel that has to be produced, does not represent any inconvenience, but it is in fact an advantage: many production routes could be exploited, meaning security of energy supply and sustainable development.

Apart from a fuel, it is also an energy carrier, being considered one of the energy vectors of the future, together with the electricity.

In conclusion (II)

Fuel cells are electrochemical devices, joining characteristics from both batteries (converting chemical energy directly into electricity) and engines (powering an application as long as they are supplied with a fuel).

Having no moving parts allows to achieve great electrical efficiencies (around 50%), do not needing a high degree of maintenance. Besides that, their degree of independence between efficiency and size also allows to develop from very low to large output applications (from W to hundreds of kW, or even MW).

- Hynergreen's overview
- Why renewable Hydrogen?
- Facing the Hydrogen Economy
- Renewable Hydrogen production

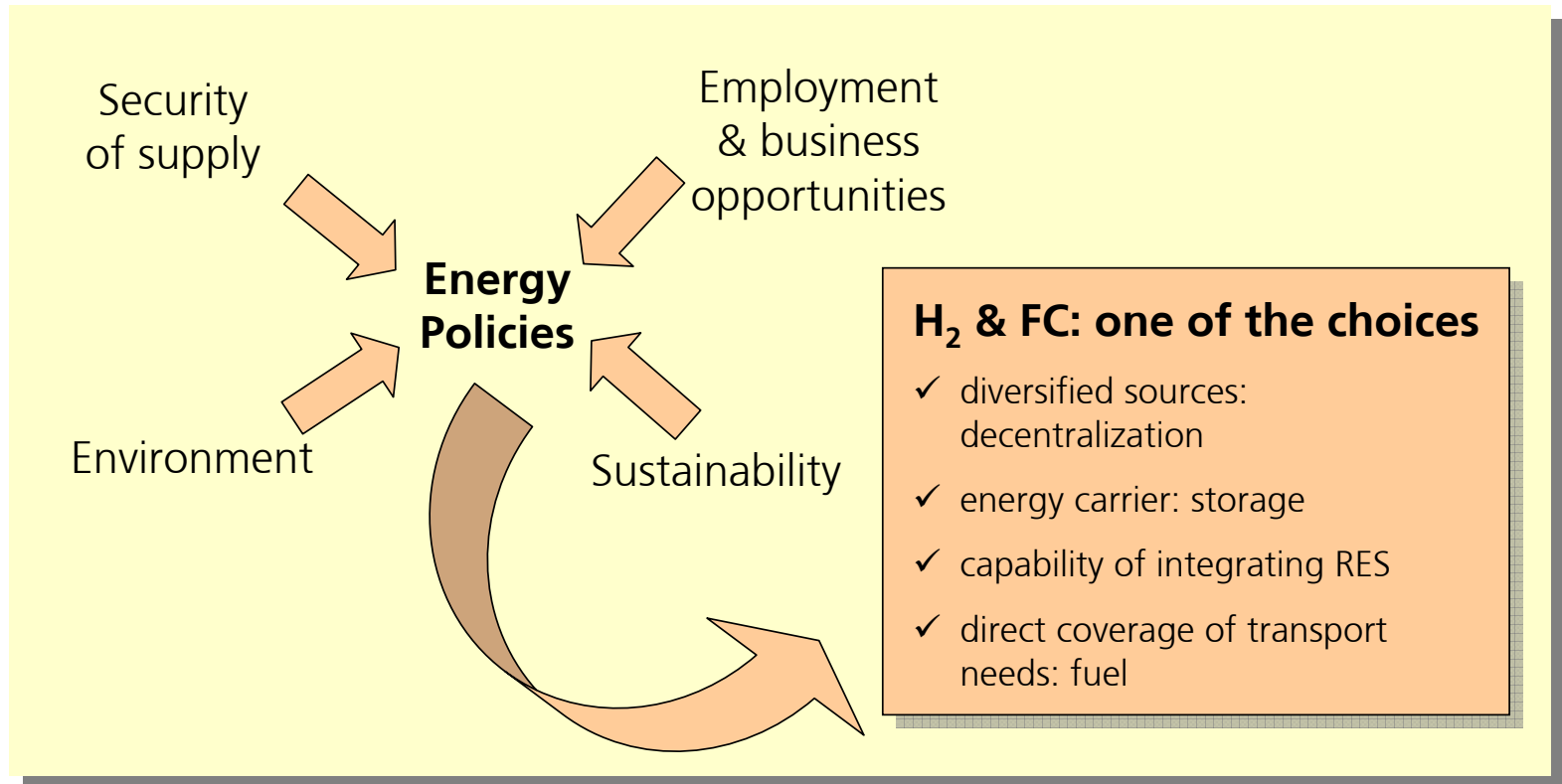

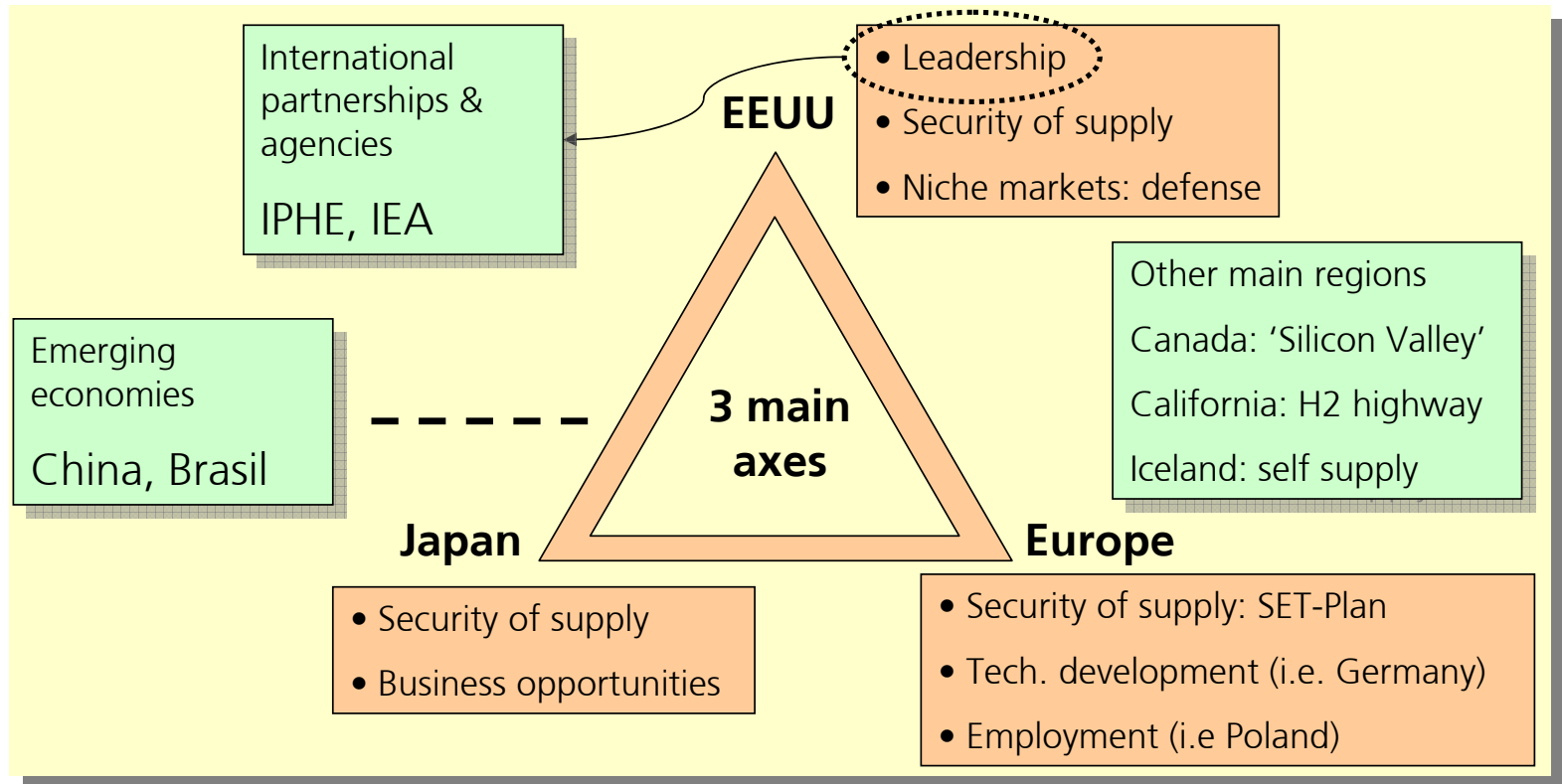

International key stakeholders

- ❖ US Department of Energy, DoE
- US Department of Transport, DoT
- US Department of Defense, DoD
- ❖ Japanese Ministry of Economy, Trade and Industry, METI
- International Partnership for the Hydrogen Economy, IPHE
- International Energy Agency, IEA

European key stakeholders

- ❖ Joint Technology Initiative (JTI) on Fuel Cells and Hydrogen (FCH)

Spanish key stakeholders

- Asociación Española del Hidrógeno, AeH2
- Asociación Española de Pilas de Combustible, Appice
- ❖ Plataforma Tecnológica Española del Hidrógeno y de las Pilas de Combustible, PTE-HPC

Spanish strategy

- ✓ Integration of RES
- ✓ Storage of clean energy → H₂ as an energy vector
- ✓ Coverage of transportation needs → reduction of CO₂ emissions & urban pollution

- Hynergreen's overview
- Why renewable Hydrogen?
- Facing the Hydrogen Economy
- Renewable Hydrogen production

Electrolysis from solar, wind or mini hydraulic power plants

- The electricity generated would be employed in a renewable way to produce hydrogen by electrolysis of water

High temperature thermal solar

- By employing direct methods (without going as far as the production of electric energy), hydrogen can be obtained through the rupture of water caused by the high temperatures that are achieved (water splitting) or by catalysis, among others
- This is one of the most promising long term renewable hydrogen sources

Gasification of biomass

- A hydrogen-rich synthesis gas can be obtained from the direct processing of biomass

Reforming of biofuels

- A hydrogen-rich reformed gas can be obtained, product of a rupture reaction of a biofuel (reforming, or processing more generically)

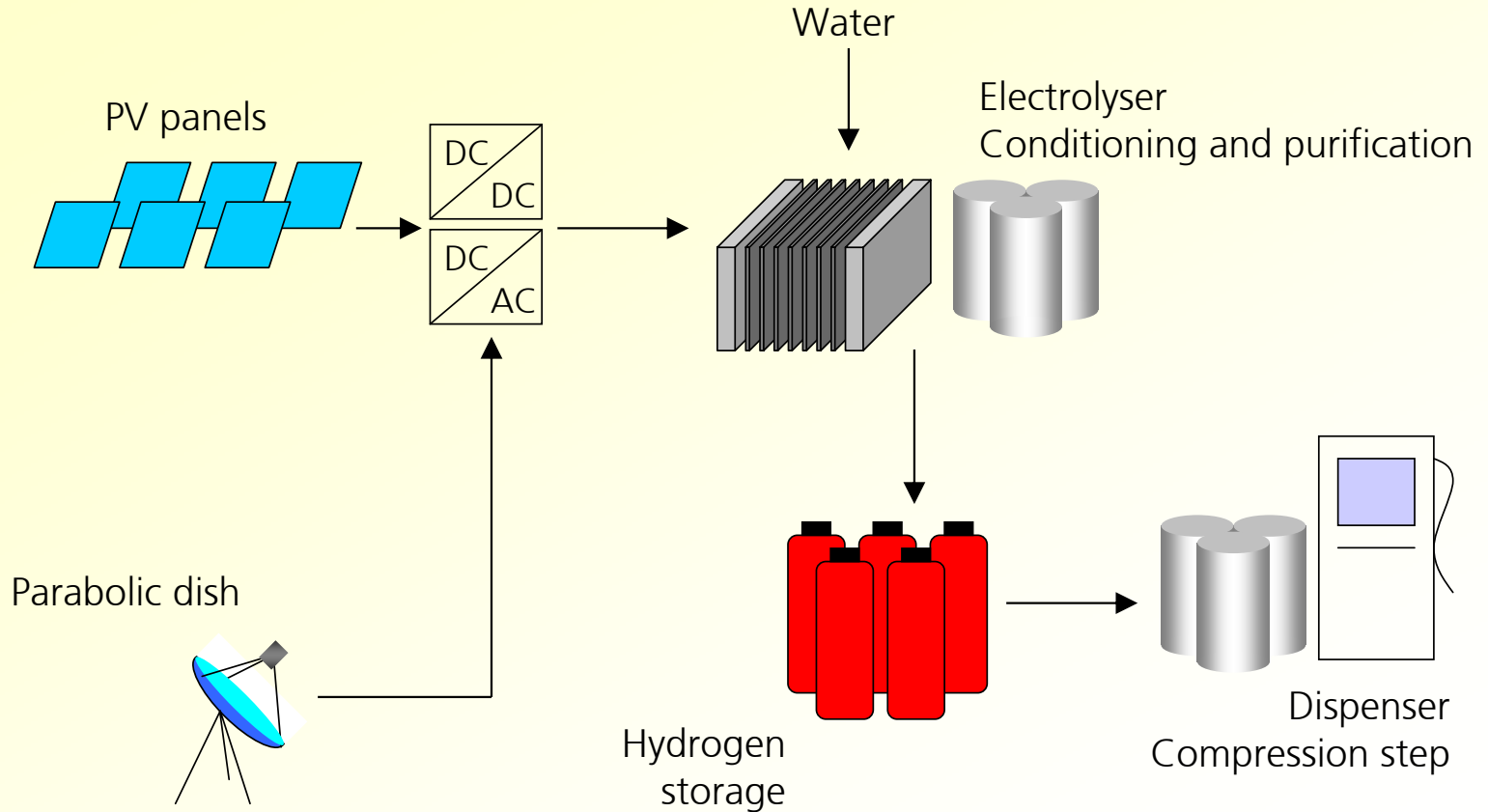





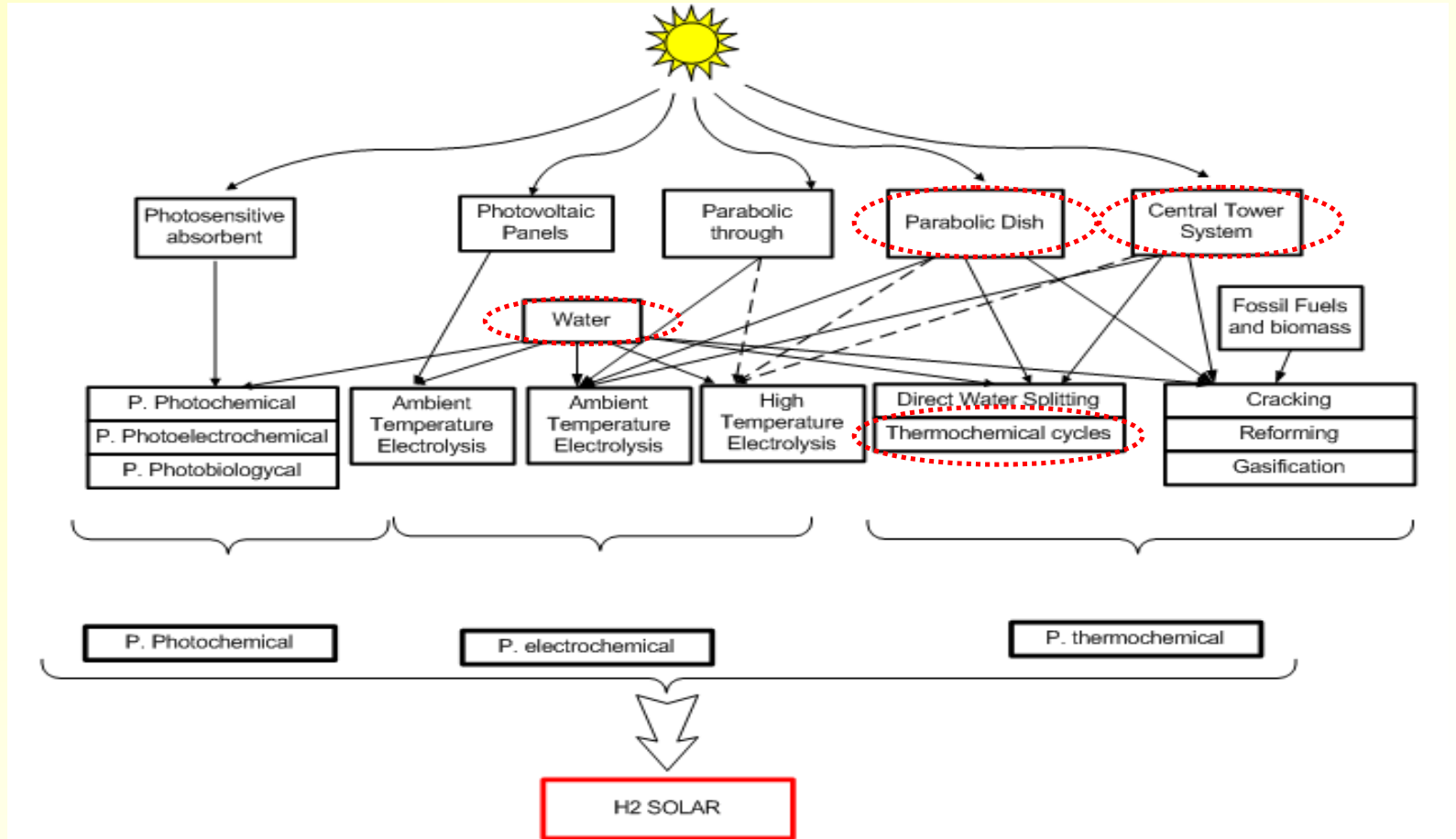







2004

Lab prototype 10 kW

2007

Industrial prototype 300 kW



2003

Lab prototype 1 kW

2002

Catalysts



2001

Feasibility





Hydrogen production from sustainable sources

Javier Brey, Hynergreen Technologies, S.A.

December 9th, 2010